

See discussions, stats, and author profiles for this publication at: <https://www.researchgate.net/publication/379484910>

Investigation of the Effect of Built-Up Edge on Chip Morphology at the Cutting Edge During Turning Operation

Article in *Journal of Polytechnic* · April 2024

DOI: 10.2339/politeknik.1432815

CITATION

1

READS

105

2 authors, including:



Kemal Yaman

Ostim Technical University

49 PUBLICATIONS 158 CITATIONS

SEE PROFILE



POLİTEKNİK DERGİSİ

JOURNAL of POLYTECHNIC

ISSN: 1302-0900 (PRINT), ISSN: 2147-9429 (ONLINE)

URL: <http://dergipark.org.tr/politeknik>



Investigation of the effect of built-up edge on chip morphology at the cutting edge during turning operation

Tornalama operasyonu sırasında oluşan takım ucu yığıntı kenarın talaş şekline etkisinin incelenmesi

Yazar(lar) (Author(s)): Kemal YAMAN¹, Zafer TEKİNER²

ORCID¹: 0000-0003-3063-391X

ORCID²: 0000-0003-1400-614X

To cite to this article: Yaman K. and Tekiner Z., “Investigation of the effect of built-up edge on chip morphology at the cutting edge during turning operation”, *Journal of Polytechnic*, 27(6): 2325-2333, (2024).

Bu makaleye şu şekilde atıfta bulunabilirsiniz: Yaman K. ve Tekiner Z., “Investigation of the effect of built-up edge on chip morphology at the cutting edge during turning operation”, *Politeknik Dergisi*, 27(6): 2325-2333, (2024).

Erişim linki (To link to this article): <http://dergipark.org.tr/politeknik/archive>

DOI: 10.2339/politeknik.1432815

Investigation of the effect of built-up edge on chip morphology at the cutting edge during turning operation

Highlights

- ❖ Investigating the mechanism of Built-Up Edge (BUE) formation
- ❖ Relationship between cutting force and feed rate
- ❖ Relationship between chip curl-up radius and cutting speed
- ❖ Cross-correlation between BUE and surface roughness
- ❖ Understanding cutting mechanis.

Graphical Abstract

Investigating Built-Up Edge (BUE) formation is crucial in engineering, impacting tool wear, surface quality, and tool life. This research explores the influence of cutting speed on BUE and chip morphology, revealing insights for optimizing machining parameters and achieving longer tool life, quality surfaces, and cost-effective production.

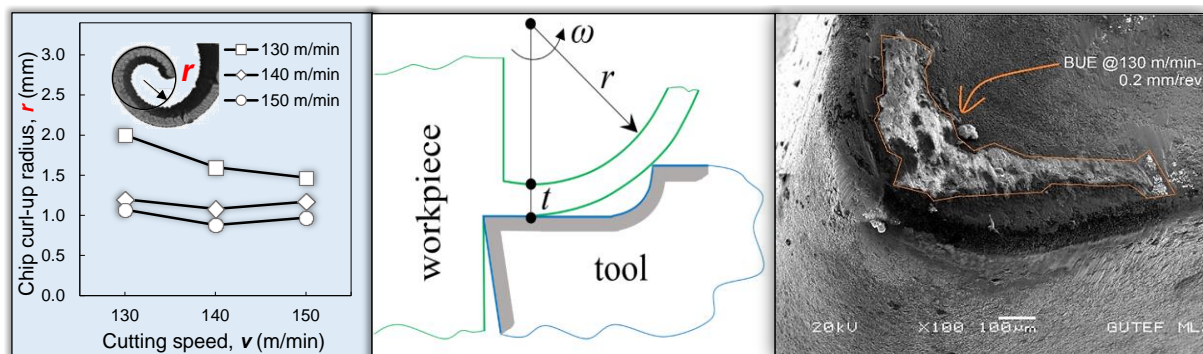

Figure. The effect of built-up edge on chip morphology

Aim

Investigation of the effect of built-up edge on tool wear and work part surface quality in turning operations

Design & Methodology

It was studied experimentally. The build-up edge tool tip SEM images formed in the cutting experiments were examined in detail and the data were processed.

Originality

The relationship between chip curl-up radius and tangential speed was examined

Findings

Increasing the cutting speed reduced the formation of ragged edges and therefore the rash edge wear.

Under constant feed rate, as the cutting speed increased, the average surface roughness decreased and the quality of the test sample surface increased.

It has been observed that the cutting force decreases with the cutting speed but increases with the feed rate.

Conclusion

Increasing the cutting speed reduced the formation of ragged edges and therefore the rash edge wear. Under constant feed rate, as the cutting speed increased, the average surface roughness decreased and the quality of the test sample surface increased. It was observed that BUE formation decreased as the cutting speed increased. It was observed that the chip curl radius and chip thickness decreased with the cutting speed but increased with the feed rate. It was also found that the cutting force decreased with the cutting speed but increased with the feed rate.

Declaration of Ethical Standards

The author of this article declares that the materials and methods used in this study do not require ethical committee permission and/or legal-special permission.

Investigation of the Effect of Built-Up Edge on Chip Morphology at the Cutting Edge During Turning Operation

Research Article/Araştırma Makalesi

Kemal YAMAN^{1*}, Zafer TEKİNER²

¹Department of Industrial Design, Architecture and Design Faculty, OSTİM Technical University, 06374, Ankara, Türkiye

²Department of Manufacturing Engineering, Faculty of Technology, Gazi University, Ankara Türkiye
(Geliş/Received : 06.02.2024 ; Kabul/Accepted : 08.03.2024 Erken Görünüm/Early View :01.04.2024)

ABSTRACT

Investigating the mechanism of Built-Up Edge (BUE) formation, which increases tool wear and leads to a decrease in surface quality and tool life, is a critical aspect in engineering applications. A detailed examination of this mechanism holds great importance for extending tool life, reducing workpiece surface roughness, and ultimately lowering tool and production costs. Currently, theoretical, experimental, and numerical studies on this formation mechanism are still ongoing. In this research, the effects of cutting speed on the BUE formation mechanism and the resulting chip morphology were examined in detail, while keeping the cutting depth and feed rate constant. Experimental studies have shown that cutting speed directly influences the formation of BUE and the resulting chip morphology. The extent of this effect, along with details related to chip morphology and BUE formation, was analyzed by comparing scanning electron microscope images. Additionally, the relationship between cutting force values read from the machine monitor during cutting and cutting speed was also investigated. This research highlights the potential to achieve a longer tool life, high-quality workpiece surfaces, and cost-effective production through the optimization of parameters in the workpiece machining process.

Keywords: Cutting speed, built-up edge, chip morphology, tool wear, surface roughness.

Tornalama Operasyonu Sırasında Oluşan Takım Ucu Yığıntı Kenarın Talaş Şekline Etkisinin İncelenmesi

ÖZ

Takım aşınmasını artırarak iş parçası yüzey kalitesinin ve takım ömrünün azalmasına sebep olan yığıntı kenar (ing. Buil-Up edge) oluşum mekanizmasının incelenmesi, mühendislik uygulamalarında kritik bir konudur. Bu mekanizmanın ayrıntılı bir şekilde ele alınması, takım ömrünün artırılması, iş parçası yüzey pürüzlülüğünün düşürülmesi ve nihayetinde takım ve üretim maliyetlerinin düşürülmesi açısından büyük öneme sahiptir. Şu anki aşamada, bu oluşum mekanizması üzerindeki teorik, deneysel ve sayısal çalışmalar halen devam etmektedir. Bu araştırmada, kesme derinliği ve ilerleme hızı sabit tutularak kesme hızının yığıntı kenar oluşum mekanizması ve işleme sonrası oluşan talaş morfolojisine olan etkileri detaylı bir şekilde incelenmiştir. Gerçekleştirilen deneysel çalışmalar, kesme hızının yığıntı kenar oluşumunu ve oluşan talaş morfolojisini doğrudan etkilediğini göstermiştir. Bu etkinin boyutu, talaş morfolojisi ve yığıntı kenarın oluşumuyla ilgili detaylar, çekilen taramalı elektron mikroskop fotoğrafları üzerinden karşılaştırılarak analiz edilmiştir. Ayrıca, kesme sırasında tezgâh monitöründen okunan kesme kuvveti değeriyle kesme hızının ilişkisi de incelenmiştir. Bu araştırma, iş parçası işleme sürecindeki parametrelerin optimize edilmesiyle daha uzun takım ömrü, yüksek kaliteli iş parçası yüzeyleri ve düşük maliyetli üretim sağlama potansiyelini ortaya koymaktadır.

Anahtar Kelimeler: Kesme hızı, yığıntı kenar, talaş morfolojisi, takım aşınması, yüzey pürüzlülüğü.

1. INTRODUCTION

Build Up Edge (BUE), generally occurs during the machining of relatively ductile materials at low speeds [1-2]. This accumulation of material at the cutting edge in the mouth region occurs as a result of the strong adhesion of the processed material to the cutting edges and the subsequent buildup over time, forming protrusions on the cutting edge. Particularly in drilling operations, the accumulation at the cutting tool edge is a significant issue. The formation of edge buildup has been reported to cause substantial deviations in

cutting depth and hole- diameter tolerances since it affects effective cutting depth and hole-diameter [3-5]. This buildup can be minimized by using positive rake angle tools, employing tools with very low surface roughness, using enhanced lubricating coolants, directing high-pressure coolant directly to the chip surface, and generally using high cutting speeds [6-7]. On the other hand, it has been suggested that the formation of buildup edge is more closely related to material properties, particularly when machining at very high cutting speeds (High-Speed Machining, HSM), where the workpiece

*Corresponding Author (Sorumlu Yazar)
e-posta: kemal.yaman@ostimteknik.edu.tr

material in the cutting zone and especially in the secondary deformation zone becomes soft and ductile [2].

Build-up edge wear is a type of wear significantly dependent on temperature and cutting speed [7]. Undesirable, it results from the material welding onto the tool surface, causing particle detachment from the tool surface. The mechanism of BUE formation is directly related to the relationship between the workpiece and the tool [1-9]. Atlati and others have indicated, based on their experimental and numerical studies on Aluminum alloy (2024-T351) material during cutting, that the increase in local friction during cutting extends the adhesion length, triggering debris edge formation. According to numerical results, the sudden or gradual increase in local frictions noticeably affects parameters such as workpiece processing speed and plastic strain values in thermo-mechanical zones. It has been observed that as friction increases, the flow of workpiece material at the tool edge slows down, resulting in increased chip adhesion [7, 10]. Similarly, on UNSA92024 aluminum alloy, Parra and others have examined the build-up layer (BUL) and wear formation mechanism under dry turning conditions. They observed the formation of the first debris layer (BUL) on the flank surface of the tool, with a composition close to pure aluminum. Because the melting temperatures of alloys added to the melting temperature of aluminum are lower, a metallurgical content close to pure aluminum is formed in the deposited region. After the formation of the initial debris edge layer, the tool geometry and cutting-edge microstructure undergo changes, creating conditions that facilitate adhesion [11-12]. This new geometry and microstructure accelerate chip accumulation by forming the fundamental mechanism for subsequent BUE formation [11, 13, 14].

In another study on the micro-milling of Titanium alloy, where BUE formation on a single-tooth cutting tool was examined, it was reported that BUE formation increases when the cutting tool relief angle is low. While BUE formation is largely under high cutting loads, an increase in cutting speed was stated not to be effective in BUE formation. In a study examining the effect of the tool edge radius [14-15], it was mentioned that the flow of chips during cutting is directly related to the tool edge radius. They expressed that larger cutting forces and a higher susceptibility to BUE formation are measured in tools with a larger edge radius compared to sharp-edged tools [2, 14].

Childs [16] expressed that elongation hardening resulting from plastic deformations during cutting is the behavior that causes the formation of BUE. He demonstrated through numerical analyses that elongation hardening triggers the formation of discontinuous chips by inducing slip errors in the microstructure of the cut material during cutting. Elongation hardening, on the other hand, is primarily attributed to the increased ambient temperature due to friction. Studies in the literature indicate that the ambient temperature generated during cutting is a fundamental factor in the mechanism of BUE formation

and related wear on the workpiece and cutting tool. In an experimental study where the cutting environment was cooled with a cryogenic compressed air jet [17], it was observed that the BUE formation occurred in very small dimensions.

It has been stated that the forces occurring during cutting are at much lower levels than in dry cutting. Chip shapes formed during machining are an important indicator for understanding the cutting process. For this reason, detailed information about chip types and shapes is presented in this section. Chips are formed in different types depending on the type of material being processed, cutting speed, feed rate, cutting depth and tool geometry parameters. Chip type is an important factor that provides information about cutting conditions and surface quality. In addition, chip type also affects the difficulty or ease of machining. Long and continuous chip flow causes it to become entangled in the tool or bench, deteriorate the material and surface quality, and damage the cutting edge. Three types of chips are formed according to the formation mechanism. These are continuous chip (flowing chip), discontinuous chip (discontinuous or broken chip) and built-up chip (BUE) [8-9].

Continuous chip formation typically occurs as a result of processing ductile materials at high speeds. Continuous chips are formed through the continuous deformation of the material in front of the cutting tool without macro-level cracking, as the chips are continuously removed with the deformation of the material. Due to high deformation, the chips harden, and increased hardness enhances tool wear. Continuous chips can take the form of bands, spirals, or various helical shapes. This type of chip formation occurs under conditions of ductile workpiece material, low cutting depth, low feed rate, sharp cutting-edge tools, large chip angle, high cutting speeds, and the use of cutting fluid for tool and workpiece cooling, and minimum chip flow resistance [8]. During the formation of discontinuous chips, the material undergoes excessive plastic deformation, and if the material is brittle, partial fracture occurs in the primary deformation zone along with the partially formed chips. Under these conditions, the chips are segmented, and the resulting chips are discontinuous. The cutting force experiences the lowest value during chip compression and the highest value during chip separation. The loading of the tool on the chip surface is inversely proportional to this. Compared to continuous chip formation, the amplitude of periodically varying cutting forces is large, and the frequency is small [8]. In the Built-Up Edge (BUE) type, it occurs when the continuously emerging chip adheres to the cutting tool surface along the machined surface. At low cutting speeds where cooling fluid is not used, due to the compressive force applied to the metal in front of the cutting tool and the excessive friction, the chip undergoes continuous deformation, resulting in chip separations along a plane perpendicular to the cutting plane. Small particles separated from the chip adhere to the tool. These particles, accumulating by sintering on the tool, form the BUE in the secondary

deformation zone. BUE, which is harder than the ejected chip, can be stable or unstable. Part of the unstable BUE is removed by the exiting chip, while another part separates from the chip during cutting and embeds into the machined surface, negatively affecting surface roughness. Additionally, very hard BUE contributes to the wear of the cutting edge. Stable BUE, on the other hand, leads to an increase in sliding stresses at the cutting tool edge and the effective chip angle, restricting the contact area between the cutting edge and the chip, thereby increasing cutting forces. Such processes adversely affect the surface quality of the material [18].

When the chips formed during processing are examined in terms of shape, it is understood from the studies that these shapes depend on many different variables. The chip shapes resulting from this study were evaluated mainly in terms of machinability. Although continuous chips are formed in band form, spiral or helical shapes, the priority chips in terms of machining are short spiral and helical shaped chips. Long chip formation is dangerous for the operator, reduces efficiency in terms of the time required for chip removal, and may deteriorate the quality of the machined surface [8].

2. MATERIAL AND METHOD

The machining experiments of test specimens prepared from SAE 1030 steel material were conducted on a CNC turning center, Goodway GA-2800L. Machining was performed by removing chips at a constant feed rate of 0.20 mm/rev and a fixed thickness of 2.50 mm at different cutting speeds of 130, 140, and 150 m/min. The amounts of built-up edge formation on the cutting tool were compared through SEM images. The tensile test graph of the SAE 1030 steel used in the experiments is presented in Figure 1. According to the tensile test, the average elongation was 38.6%, and the maximum tensile strength values were read from the tensile testing machine as 76,582 N for three different test specimens.

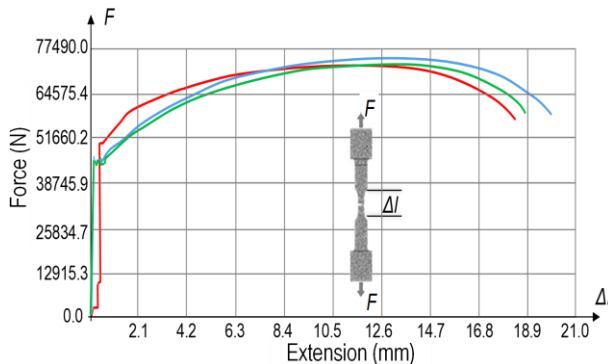

Figure 1. Tensile test results of test samples

Test materials were prepared considering the TS 10329 standard with a length/diameter ratio less than 10/1. The chemical composition of the samples in % is given in Table 1. A tailstock hole was drilled at the end of each sample to be suitable for processing between the chuck and the tailstock.

Table 1. Chemical composition of SAE 1030 material used in experiments

Component	C	Cr	Mn	Mo	Ni	Cu	S
Rate (%)	0.31	0.07	0.67	5.00	0.09	0.292	0.027

According to the TS 10329 standard, if the cutting tool has a hard metal or ceramic-tipped end, the tips should be of the mechanical clamping type. Tips attached to the body with hard solder or metal coating should not be used as a reference cutting tool. The cutting tool must be connected to the machine in the correct orientation. In this context, the cutting edge of the tool should be at the level of the tool axis, and the cutting body should be perpendicular to the axis of rotation. In cutting experiments, a cutting insert of type IC8250 with a 0.4 mm nose radius, following the TS-10329 standard, was used. The inserts were coated with TiAlN using the Physical Vapor Deposition (PVD) method. The tool holder with code number DDJNR 2525 M-15 was used as the cutter. To ensure no chip formation and stable cutting, the samples were connected between the chuck and the tailstock, as shown in Figure 2.

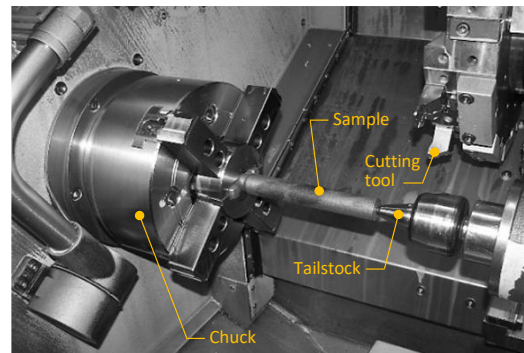

Figure 2. Test sample prepared for processing between the chuck and the tailstock

The Mitutoyo SURFTEST-301 model roughness measurement device was used to measure surface roughness. A tool microscope was employed for pre-measurements of wear on cutting tools. Photographs of the chips removed from the test specimen were taken. Edge Build-Up (BUE) formations were examined in stages by capturing SEM images. Samples taken from the chips generated during machining were measured using a digital caliper. For each cutting parameter, ten chip samples were taken, and their thicknesses and radii were measured. Average thicknesses and standard deviations were calculated. The relationships between the obtained chip shapes and BUE wear were investigated

3. RESULTS AND DISCUSSION

By increasing the cutting speed (130,140,150 m/min @ 0.20 mm/rev), SEM images were taken to observe the BUE formation on the cutting tool according to the constant cutting depth and feed rate and are shown as Figure 3a, Figure 3b and Figure 3c. When SEM images

are examined, under constant cutting depth (chip thickness) and feed rate, the formation of stacked edges decreases as the cutting speed increases. While the largest accumulation occurs at a cutting speed of 130 m/min, an area approximately half the size of the previous affected area was affected at a cutting speed of 140 m/min. At a cutting speed of 150 m/min, it was observed that stacked forms in a much smaller area.

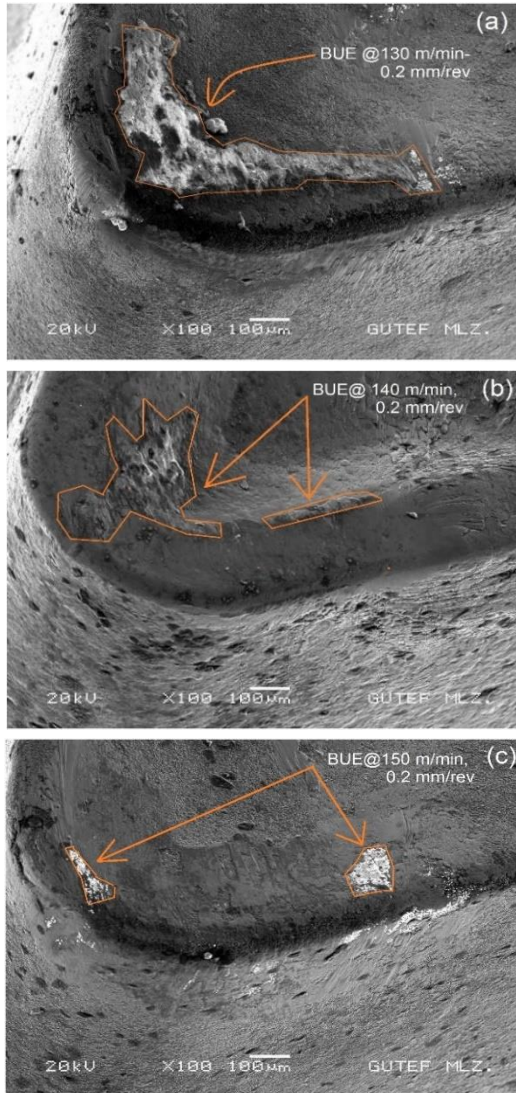

Figure 3. BUE formations at variable cutting speeds of (a) 130 m/min, (b) 140 m/min and (c) 150 m/min at a constant cutting depth and constant feed rate (0.2 mm/rev)

At low cutting speeds where the temperature is low [19-20], in cases where coolant is not used or is insufficient, the continuous deformation of the chip emerging in front of the cutting tool results in smaller particles breaking off from the chip, which then contribute more to the welding on the tool. As the speed increases and effective cooling is applied, the opportunity for the particles breaking off from the chip to weld onto the tool surface is prevented. Consequently, the welding area or affected region decreases. BUE, which is harder than the ejected chip, increases the surface roughness of the produced part by

embedding into the machined surface. However, it is clearly observed from SEM images that a very hard BUE also causes wear on the cutting edge. The best surface quality was achieved at a cutting speed of 150 m/min in the cutting experiments.

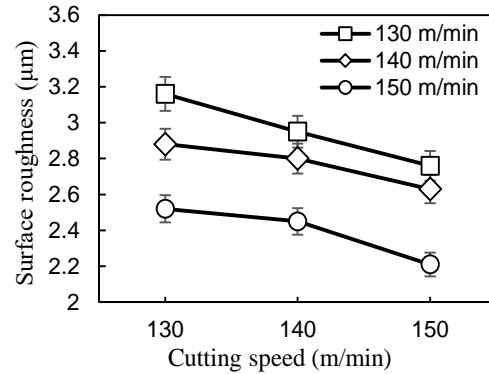

Figure 4. Variation of surface roughness according to cutting speed

It was observed that the average surface roughness value decreased when the cutting speed was increased from 130 m/min to 140 m/min. When the cutting speed was increased to 150 m/min, the average surface roughness value reached its lowest value of 2.188 μm , meaning that the best quality surfaces were obtained at the highest cutting speed (See Table 2 and Figure 4). The relationship between cutting speed and surface quality is in agreement with similar studies [8-9, 21-22].

Looking at most cutting plane model-based analyses, the chip flow rate is assumed to remain constant throughout the chip thickness and the chip is considered flat. This means that in real machining processes, when the tool-chip natural contact length is reached, the chip moves away from the tool surface and curls. Chip curling was first studied in the literature by Cook et al. [23]. In this study, in addition to examining the kinematics of chip curl, they evaluated the resulting edge accumulation (BUE) and the effects of additives in the workpiece material. They considered chip curl as a cause rather than a result and suggested that BUE and crater may be formed by a predetermined chip curl feature. They presented various experimental results to support their claims.

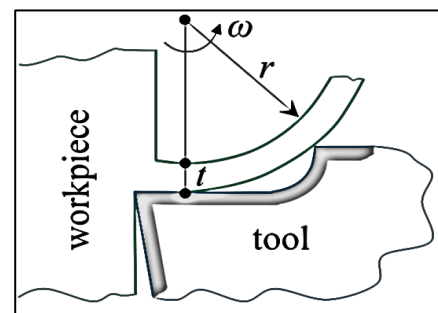

Figure 5. Formation of chip curl-up radius

Table 2. Surface roughness measurement results of test samples

Cutting speed(m/min)	Feed rate(mm/rev)	Sample surface roughness(μm)					Average surface roughness (μm)	Standard deviation
		1	2	3	4	5		
130	0.20	3.16	2.95	2.76	2.85	2.72	2.880	0.161
140		2.88	2.80	2.63	2.57	2.48	2.642	0.097
150		2.52	2.45	2.21	2.19	2.07	2.188	0.126

Table 3. Surface roughness measurement results of test samples

Cutting speed(m/min)	Feed rate(mm/rev)	Sample surface roughness(μm)					Average surface roughness (μm)	Standard deviation
		1	2	3	4	5		
130	0.20	3.16	2.95	2.76	2.85	2.72	2.880	0.161
140		2.88	2.80	2.63	2.57	2.48	2.642	0.097
150		2.52	2.45	2.21	2.19	2.07	2.188	0.126

Table 4. Curl-up radius measurements of chip samples formed at different cutting speeds

Cutting speed (m/min)	Feed rate (mm/rev)	Sample chip curl-up radius dimensions (mm)										Average radius (mm)
		1	2	3	4	5	6	7	8	9	10	
130	0.20	2	1.7	1.5	1.9	1.5	1.3	1.5	1.2	1.8	1.4	1.58
140		1.15	1.1	1.1	1.15	1	1.1	1.15	1.3	1.7	1.9	1.31
150		1.05	1	1	1.1	1.8	1.1	1.2	1.8	1.15	1.3	1.20

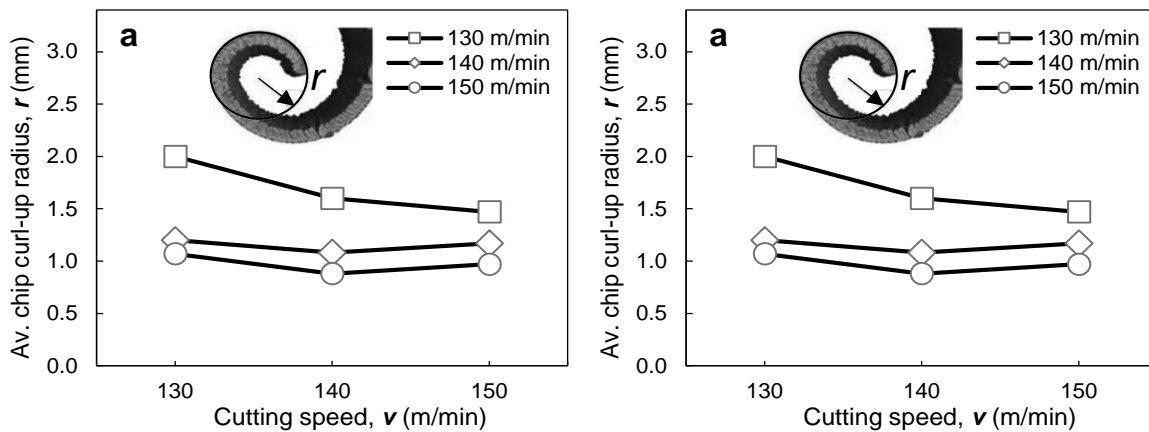

Figure 6. The relationship between cutting speed and (a) chip curl-up radius (b) chip thickness

They tried to explain the chip curling and straightening mechanism with the help of plastic theory, but a complete plasticity solution was not given. All these published studies take into account that the process is handled only under orthogonal conditions.

Studies in the literature describe the upward curling of chip as a natural phenomenon [24]. Others view the upward curling of the chip as a result of stable edge

deposition (Worthington and Redford [25]). Chip breaker geometries were developed according to these principles (Okushima et al. [26]). In this case, experimental measurements were taken while the cutting process was carried out only under vertical conditions (Figure 5).

The chips obtained from experimental specimens processed at various cutting speeds and constant feed parameters were measured using a digital caliper, and the

curl-up radii and chip thicknesses are presented in Tables 3 and Table 4, respectively. The measured radius and thickness data indicate that chips from specimens with lower cutting speeds have higher chip thicknesses and lower chip curl-up radii (see Figure 6a and Figure 6b).

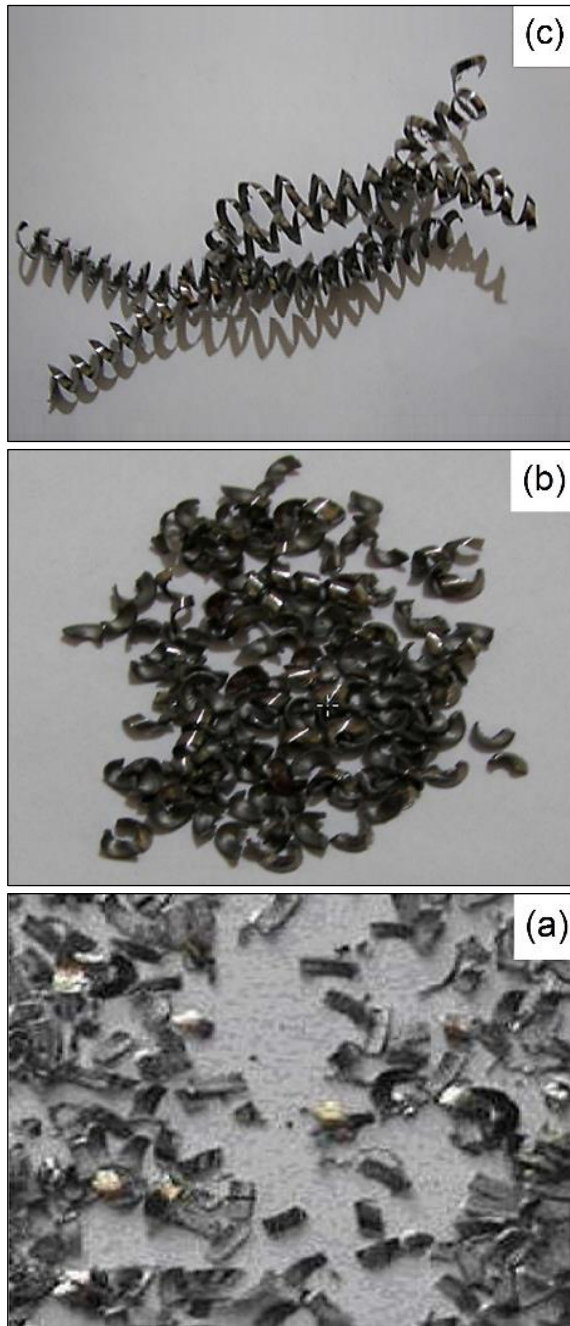

Figure 7. Chip morphologies formed under a constant feed rate of 0.2 mm/rev (a) 130 m/min (b) 140 m/min (c) 150 m/min

An increase in chip thickness makes it more difficult for the chip to flow over the cutting edge and simultaneously causes an increase in heat in that region [9]. Increasing the cutting speed has been observed to result in an increase in chip curl-up radius and a decrease in chip thickness. The heat generated by the increased cutting speed facilitates easier flow of the chip over the

experimental specimen. The reduction in curl-up radius and chip thickness with an increase in cutting speed is consistent with the literature [27-31].

When the cutting speed was increased from 130 m/min to 150 m/min, the average chip curl-up radius increased from 1.20 mm to 1.58 mm. As the cutting speed increased, the flow rate of the chips increased and the temperature increased due to the color of the chips in the cutting zone. When the cutting speed was 140 m/min, the color of the chip in the cutting zone became light, close to yellow (Figure 7). At the same time, the chips obtained according to this cutting parameter showed a homogeneous distribution. Accordingly, the best surface quality was obtained at a cutting speed of 150 m/min. The resulting chip shapes are shown in Figure 8 in 1/1 scale photographs as (a) 130 m/min, (b) 140 m/min and (c) 150 m/min. As stated before, increasing cutting speed significantly prevents BUE formation and increases cutting performance [13, 21, 29, 32].

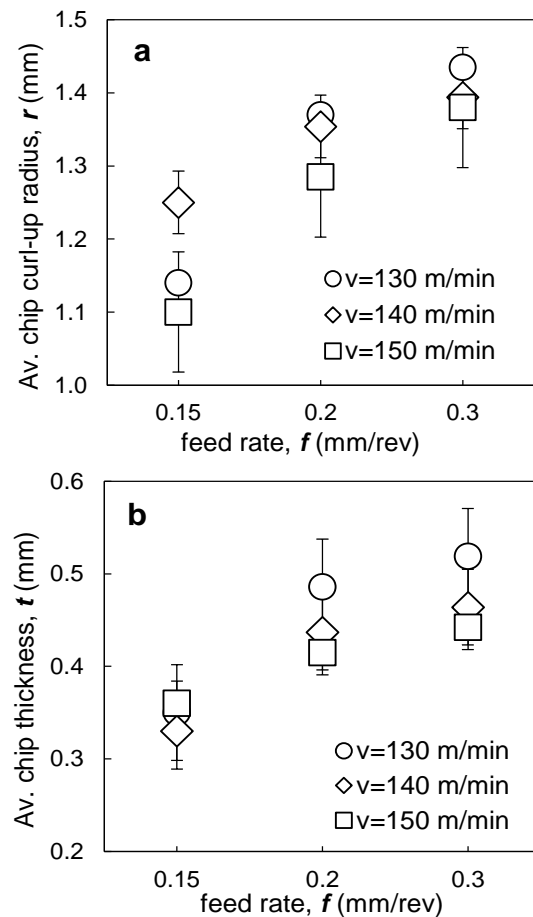

Figure 8. Variation of feed rate with (a) average chip curl-up radius and (b) average chip thickness

As the feed rate increases during machining, the average chip curl-up radius increases due to the increase in chip thickness. The increase in chip thickness causes the chip to show higher resistance against the forces that bend the chip, and as a result, it reduces the tendency of the chip to curling and causes the curl radius to increase. This

situation is shown in Figure 8a and Figure 8b with a standard deviation of 5%. In Figure 8a, under the condition of a constant 130 m/min cutting speed, when the feed rate doubles from 0.15 mm/rev to 0.30 mm/rev, the average chip curl-up radius increases by approximately 30% from 1.1 mm to 1.4 mm. When the feed rate is kept constant, it is observed that the chip curl-up radius decreases, on the contrary, as the cutting speed increases. When the cutting speed is kept constant, as the feed rate increases, the surface roughness and average chip thickness increase, meaning the sample surface quality decreases significantly (Figure 8b). The similar results are consistent with previous studies [24, 28, 30-31, 33-35].

The cutting forces were obtained by exploiting the feature of the machining center. During processing on the CNC machine, cutting loads generated on the machine axes can be monitored as a percentage. The loads on the X and Z axes during cutting, expressed as a percentage, were obtained based on the variation in cutting speeds. As the cutting speed increased, the loads on the machine axes, as read from the machine monitor, decreased from 1.63 kN to 1.39 kN (Refer to Table 5 and Figure 9). This reduction is attributed to the decrease in chip contact length or contact area as the cutting speed increases [7, 19-20, 21, 32]. As the contact area decreases, friction decreases. Cutting forces and the heat generated in the environment lowers with friction reduction.

Table 5. Cutting force values depending on cutting speed at a constant feed rate of 0.2 mm/rev

Cutting speed (m/min)	Cutting force (%)	Cutting force (kN)
130	35	1.63
140	32	1.52
150	23	1.39

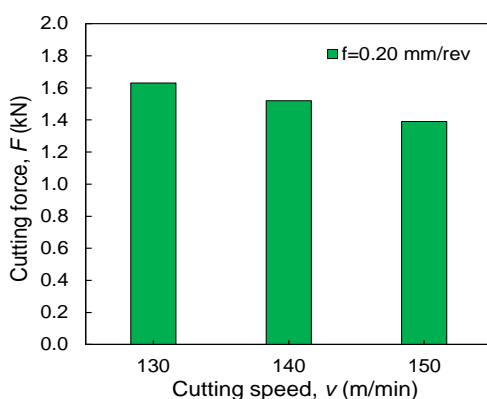

Figure 9. Variation of cutting speed with axial force at a constant feed of 0.2 mm/rev

Considering Figure 9, a decreasing trend of approximately 15% is observed in cutting force values as the cutting speed increases from 130 m/min to 150 m/min. It can be stated that this reduction in heat in this region allows the chips to flow more easily, preventing

adhesion to the surface, as they are efficiently removed from the environment by the cooling fluid. As the cutting speed increases, a continuous chip formation is observed. Similar results are described in the literature [20-21, 32]. In this study, which investigates the effect of cutting speed on the formation of built-up edge (BUE), the optimal cutting speed is determined as 150 m/min, considering surface roughness, chip characteristics, and cutting forces, under a constant feed rate of 0.20 mm/rev.

When examining the relationship between cutting force and feed rate, it is observed that as the feed rate increases, the cutting tool engages more with the workpiece, leading to higher friction and cutting load on the lathe spindle. Consequently, the cutting force acting on the lathe spindle increases. When the cutting speed is held constant, an increase in the feed rate results in a nearly proportional rise in cutting force, and as the constant cutting speed value increases, the cutting force gradually decreases.

This phenomenon is clearly evident in Figure 10a and Figure 10b. Consistent with findings in the literature, similar results have been observed in studies conducted [21, 27, 29-30, 35]. Particularly, in Rao's investigation on machining Inconel 718 alloy material with cutting parameters very close to those in this study, results closely resembling this study were obtained [30].

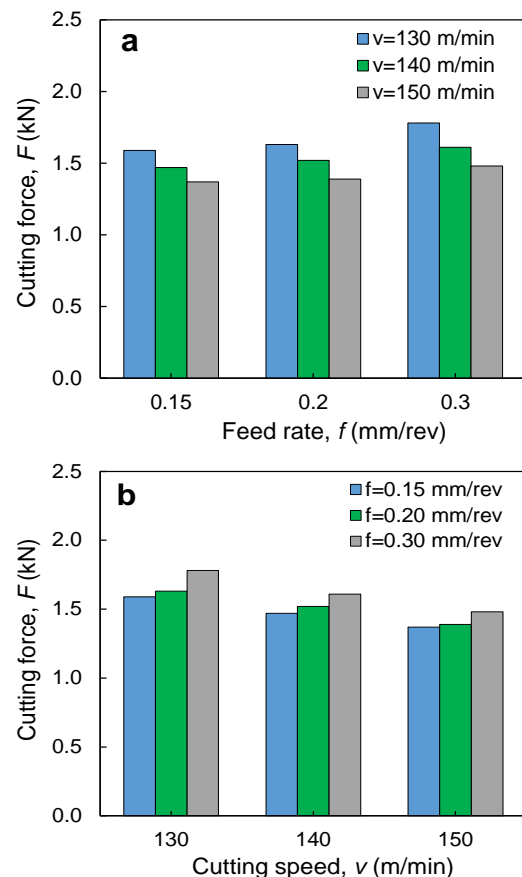

Figure 10. Cutting force variation with (a) feed rate and (b) cutting speed

4. CONCLUSION

The results summarized below were obtained in this study, where the mechanism of Built-Up Edge (BUE) formation on the cutting tool and the radius of chip curl in SAE 1030 forged steel material were investigated:

1. It was observed that under the conditions of a constant feed rate of 0.2 mm/rev, the minimum BUE formation occurred at a cutting speed of 150 m/min. An increase in cutting speed reduced BUE formation and consequently BUE wear. These results were found to be consistent with similar studies reported in the literature.
2. The increase in cutting speed from 130 m/min to 150 m/min facilitated the smoother flow of chips over the material, resulting in a reduction of the continuous chip curl-up radius from 1.58 mm to 1.20 mm.
3. Under a constant feed rate (0.2 mm/rev), when the cutting speed was increased from 130 m/min to 150 m/min, the average surface roughness decreased from 2.880 μm to 2.188 μm .
4. Analyzing the forces on the CNC machine axes, it was observed that increasing the cutting speed from 130 m/min to 150 m/min led to a decrease in cutting force from approximately 35% to 23%. As the cutting speed increased, a reduction in cutting forces occurred. On the other hand, increases in feed rate caused the cutting tool to penetrate more into the chip, leading to increased friction and consequently an increase in cutting forces. When comparing both cutting parameters, it was determined that the feed rate caused higher increases in cutting forces compared to cutting speed.

ACKNOWLEDGEMENT

We would like to thank the staff of Gazi University, Faculty of Technology, Department of Manufacturing Engineering, Material Characterization Laboratory, who contributed to the infrastructure in carrying out the experiments.

DECLARATION OF ETHICAL STANDARDS

The authors of this article declare that the materials and methods used in their study do not require ethics committee approval and/or legal permission.

AUTHORS' CONTRIBUTIONS

Kemal YAMAN: He carried out the experiments and analyzed the results.

Zafer TEKİNER: He helped to establish the experimental setup, prepared the samples and contributed to the analysis and evaluation of the experimental results.

CONFLICT OF INTEREST

The authors declare that there is no conflict of interest with third parties at every stage of the study.

REFERENCES

- [1] Çiftçi, İ., "AISI 304 Ostenitik paslanmaz çeliğin kaplanmış sementit karbür kesici takım ile işlenmesi esnasında oluşan takım aşınması", *Teknoloji*, 7(3): 489-495, (2004).
- [2] Tomac, N., Tonnessen, K., Rasch, F.O., Mikac, T., "A study of factors that affect the build-up material formation", *Published in: E. Kuljanic (Ed.) Advanced Manufacturing Systems and Technology*, CISM Courses and Lectures No. 486, Springer Wien, New York, (2005).
- [3] Batzer, S.A., Haan, D.M., Rao, P.D., Olson W.W., Sutherland, J.W., "Chip morphology and hole surface texture in the drilling of cast aluminum alloys", *J. Mater. Proc. Technol.*, 79(1-3): 72-78, (1998).
- [4] Kirschner, M., Michel, S., Berger, S., Biermann, D., Debus, J., Braukmann, D., Bayer, M., "In situ chip formation analyzes in micro single-lip and twist deep hole drilling", *Int. J. Adv. Manuf. Technol.*, 95: 2315-2324, (2018).
- [5] Mohammad, U., Basak, A., Pramanik, A., Singh, S., Krolczyk, G.M., Prakash, C., "Evaluating hole quality in drilling of Al 6061 alloys", *Materials*, 11: 2443-2456, (2018).
- [6] Özdemir, U., Erten, M., "Talaşlı imalat sırasında kesici takımda meydana gelen hasar mekanizmaları ve takım hasarını azaltma yöntemleri", *Havacılık ve Uzay Teknolojileri Dergisi*, 1(1): 37-50, (2003).
- [7] Atlati, S., Haddag, B., Nouari, M., Moufki, A., "Effect of the local friction and contact nature on the Built-Up Edge formation process in machining ductile metals", *Tribology International*, 90: 217-227, (2015).
- [8] Yaman K., Başaltın M., "Tornalama operasyonunda takım ucu yığıntı kenar oluşumunun deneysel olarak incelenmesi ve yığıntı kenarın talaş şekline etkisi", *The International Conference on Materials Science, Mechanical and Automotive Engineering and Technology*, in Cappadocia/TURKEY (IMSMATEC'19), June 21-23, (2019).
- [9] Yesilkaya, K.K., Yaman, K., "Heat partition effect on cutting tool morphology in orthogonal metal cutting using finite element method", *Mechanika*, 25(4):326-334, (2019).
- [10] Nieslony, P., Grzesik, W., Laskowski, P., Zak, K., "Numerical 3D FEM simulation and experimental analysis of tribological aspects in turning inconel 718 alloy", *Journal of Machine Engineering*, 15(1): 46-57, (2015).
- [11] Parra, A.G., Alcon, M.A., Salguero, J., Batista, M., Marcos, M., "Analysis of the evolution of the Built-Up Edge and Built-Up Layer formation mechanisms in the dry turning of aeronautical aluminum alloys", *Wear*, 302: 1209-1218, (2013).
- [12] Desaiques, J.E., Lescalier, C., Arzur, A.B., Dudzinski, D., Bomont, O., "Experimental study of Built-Up Layer formation during machining of high strength free-cutting steel", *J. Mater. Proc. Technol.*, 236: 204-215, (2016).
- [13] Davoudinejad, A., Tosello, G., Annoni, M., "Influence of the worn tool affected by Built-Up Edge (BUE) on micro end-milling process performance: A 3D Finite Element Modeling investigation", *Int. J. Precision Eng. Manuf.*, 18(10): 1321-1332, (2017).

- [14] Oliaei, S.N.B., Karpat, Y., "Built-up edge effects on process outputs of titanium alloy micro-milling", *Precision Engineering*, 49: 305-315, (2017).
- [15] Fang, N., Srinivasa, P., Mosquea, S., "A comparative study of sharp and round-edge tools in machining with built-up edge formation: cutting forces, cutting vibrations, and neural network modeling", *Int. J. Adv. Manuf. Technol.*, 53: 899-910, (2011).
- [16] Childs, T.H.C., "Ductile shear failure damage modelling and predicting built-up edge in steel machining", *J. Mater. Proc. Technol.*, 213: 1954-1969, (2013).
- [17] Sun, S., Brandt, M., Palanisamy, S., Dargush, M.S., "Effect of cryogenic compressed air on the evolution of cutting force and tool wear during machining of Ti-6Al-4V alloy", *J. Mater. Proc. Technol.*, 221: 243-254, (2015).
- [18] Wang, Z., Kovvuri, V., Araujo, A., Bacci, M., Hung, W.N.P., Bukkapatnam, S.T.S., "Built-up-edge effects on surface deterioration in micromilling processes", *J. Manuf. Processes*, 24: 321-327, (2016).
- [19] Yaman K., Özcan M., Tekiner Z., "Determination of the spinning parameters of AISI 304L stainless steel by using finite element method", *Journal of the Faculty of Engineering and Architecture of Gazi University*, 33(1): 299-311, (2018).
- [20] Yaman K., Bıçakçı N., Özgedik A., "Investigation of the drill length effect on hole tolerances", *Journal of Polytechnic*, 20(4): 765-775, (2020).
- [21] Song X., Takahashi Y., He W., Ihara T., "Study on the protective effect of built-up layer in dry cutting of stainless steel SUS304", *Precision Engineering*, 65: 138-148, (2020).
- [22] Mozammil S., Koshta E., Jha P.K., Swain P.K., "Investigation on experimental machinability & 3D finite element turning simulations of Al-4.5%Cu/TiB₂/3p composite", *Trans Indian Inst Met.*, 76(1): 225-238, (2023).
- [23] Cook N.H., Jhaveri P., Nayak N., "The mechanism of chip curl and its importance in metal cutting", *Journal of Engineering for Industry*, 85(4): 374-380, (1963).
- [24] Nakayama K., "A study on chip-breaker", *Bulletin of JSME*, 5(17): 142-150, (1962).
- [25] Worthington B., Redford A.H., "Chip curl and the action of the groove type chip former", *Int. J. Mach. Tool Des. Res.*, 13: 257-270, (1973).
- [26] Okushima K., Minato K., "On the behavior of chip in steel cutting", *Bulletin of JSME*, 2(5): 58-64, (1959).
- [27] Nobel C., Hofmann U., Klocke F., Veselovac D., "Experimental investigation of chip formation, flow, and breakage in free orthogonal cutting of copper-zinc alloys", *Int J Adv Manuf Technol*, 84: 1127-1140, (2016).
- [28] Ahmed Y.S., Paiva J.M., Veldhous S.C., "Characterization and prediction of chip formation dynamics in machining austenitic stainless steel through supply of a high-pressure coolant", *The International Journal of Advanced Manufacturing Technology*, 102: 1671-1688, (2019).
- [29] Xu, D., Feng P., Li W., Ma Y., Liu B., "Research on chip formation parameters of aluminum alloy 6061-T6 based on high-speed orthogonal cutting model", *Int J Adv Manuf Technol.*, 72: 955-962, (2014).
- [30] Rao A.S., "Effect of nose radius on the chip morphology, cutting force and tool wear during dry turning of Inconel 718", *Tribology - Materials, Surfaces & Interfaces*, 17(1): 62-71, (2023).
- [31] Dash L., Padhan S., Das S.R., "Experimental investigations on surface integrity and chip morphology in hard turning of AISI D3 steel under sustainable nanofluid-based minimum quantity lubrication", *Journal of the Brazilian Society of Mechanical Sciences and Engineering*, 42(500): 1-25, (2020).
- [32] Reis L.L.G., Junior W.M.S., Machado A.R., "Effect of cutting speed and cutting fluid on the BUE geometry of a SAE 12L14 free machining steel", *J. of the Braz. Soc. of Mech. Sci. & Eng.*, 29(2): 196-201, (2007).
- [33] Fang N., "Kinematic characterization of chip lateral-curl—the third pattern of chip curl in machining", *Journal of Manufacturing Science and Engineering*, 124: 667-675, (2002).
- [34] Devotta A., Beno T., Löf R., Espes E., "Quantitative characterization of chip morphology using computed tomography in orthogonal turning process", *Procedia CIRP*, 33: 299 - 304, (2015).
- [35] Ulaş H.B., "AISI D2 ve AISI D3 soğuk iş takım çeliklerinin delinmesinde kesme parametrelerinin kesme kuvvetleri üzerindeki etkisinin incelenmesi", *Politeknik Dergisi*, 21(1): 251-256, (2018).